

### General Description

The A8348 is a 48-channel, constant current sink, LED driver. Two external resistors set the maximum current value of all channels. A8348 also armed with 12 bit (4096 steps) grayscale PWM control and 7 bit (128 steps) current adjustment for every channel. The LED open detection indicates a broken or disconnected LED at an output terminal. A thermal protection function is featured to prevent over-heating.

- Power supply voltage range  $V_{DD} = 3.0V$  to  $5.5V$
- Current Accuracy:
  - $\pm 6\%$  (Channel to Channel)
  - $\pm 12\%$  (Chip to Chip)
- Operating Temperature:  $-40^{\circ}C$  to  $85^{\circ}C$
- Integrated Over-Temperature Protection
- LED Open Detection
- Package : LQFP128 with thermal pad

### Key Features

- 48 Constant Current Output Channels
- Drive Capability -- 0 to 40mA (Current Sink)
- Built-in 12 bit PWM Grayscale Control
- 7 bit Current Adjustment for each channel
- Fast Data Transfer Rate

### Applications

- Side Light
- Direct Back Lighting
- Main Lighting
- Monocolor, Multicolor, Full-Color LED Displays
- LED Signboards

### Application Diagram

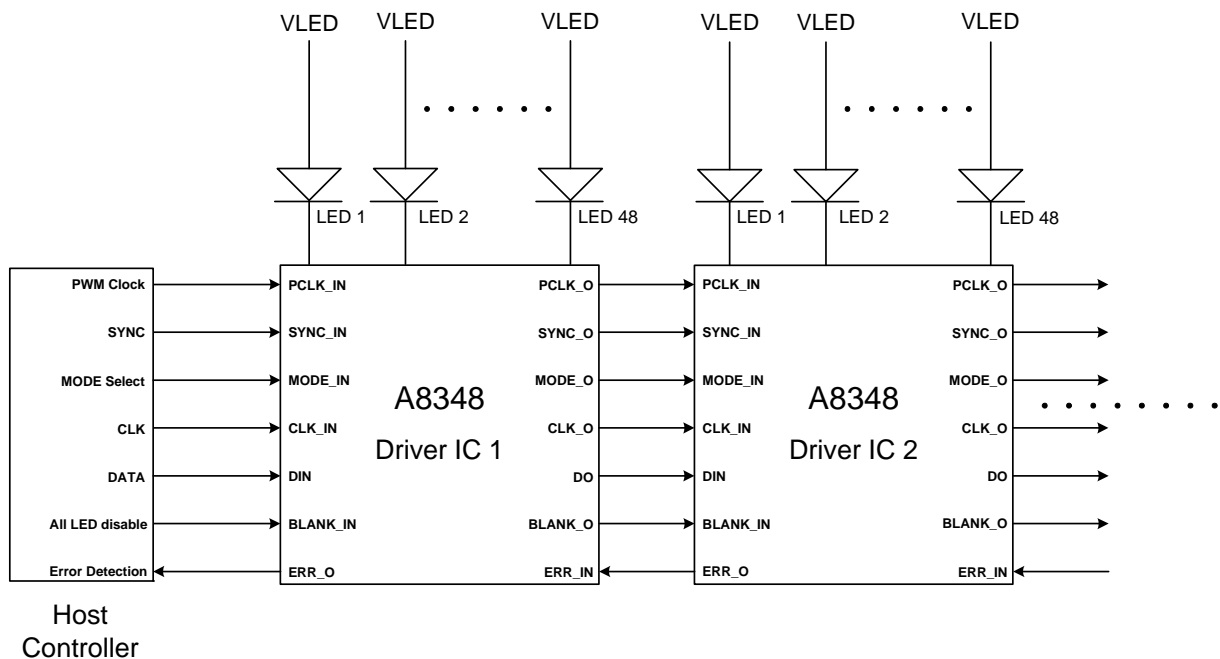

## Pin Configuration

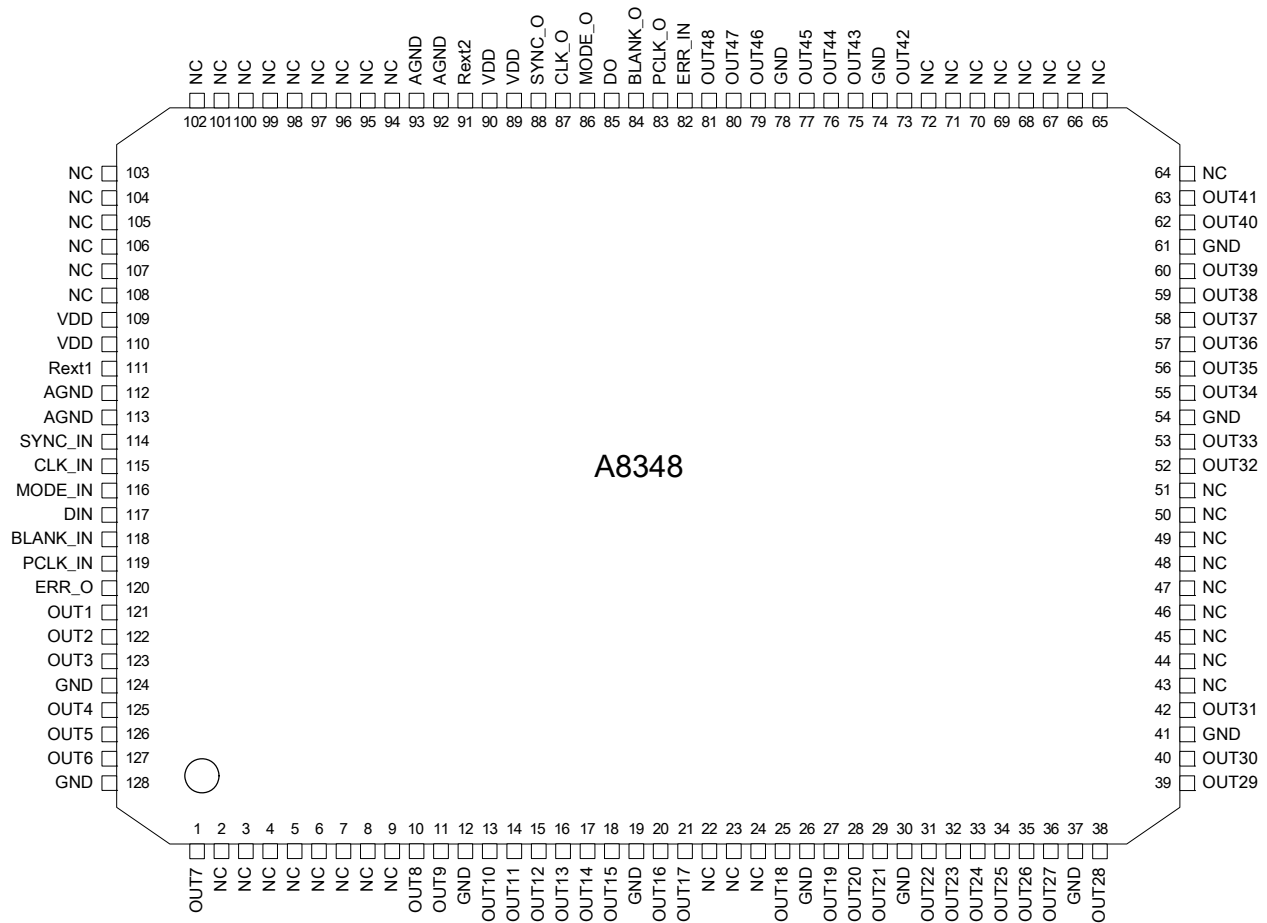

## Terminal Description

Pin number	Pin name	I/O	Description
1	OUT7	O	Constant current output 7
2	NC	-	No connection
3	NC	-	No connection
4	NC	-	No connection
5	NC	-	No connection
6	NC	-	No connection
7	NC	-	No connection
8	NC	-	No connection
9	NC	-	No connection
10	OUT8	O	Constant current output 8
11	OUT9	O	Constant current output 9
12	GND	G	Ground
13	OUT10	O	Constant current output 10



14	OUT11	O	Constant current output 11
15	OUT12	O	Constant current output 12
16	OUT13	O	Constant current output 13
17	OUT14	O	Constant current output 14
18	OUT15	O	Constant current output 15
19	GND	G	Ground
20	OUT16	O	Constant current output 16
21	OUT17	O	Constant current output 17
22	NC	-	No connection
23	NC	-	No connection
24	NC	-	No connection
25	OUT18	O	Constant current output 18
26	GND	G	Ground
27	OUT19	O	Constant current output 19
28	OUT20	O	Constant current output 20
29	OUT21	O	Constant current output 21
30	GND	G	Ground
31	OUT22	O	Constant current output 22
32	OUT23	O	Constant current output 23
33	OUT24	O	Constant current output 24
34	OUT25	O	Constant current output 25
35	OUT26	O	Constant current output 26
36	OUT27	O	Constant current output 27
37	GND	G	Ground
38	OUT28	O	Constant current output 28
39	OUT29	O	Constant current output 29
40	OUT30	O	Constant current output 30
41	GND	G	Ground
42	OUT31	O	Constant current output 31
43	NC	-	No connection
44	NC	-	No connection
45	NC	-	No connection
46	NC	-	No connection
47	NC	-	No connection
48	NC	-	No connection
49	NC	-	No connection
50	NC	-	No connection
51	NC	-	No connection
52	OUT32	O	Constant current output 32
53	OUT33	O	Constant current output 33
54	GND	G	Ground
55	OUT34	O	Constant current output 34
56	OUT35	O	Constant current output 35
57	OUT36	O	Constant current output 36
58	OUT37	O	Constant current output 37
59	OUT38	O	Constant current output 38
60	OUT39	O	Constant current output 39
61	GND	G	Ground
62	OUT40	O	Constant current output 40



63	OUT41	O	Constant current output 41
64	NC	-	No connection
65	NC	-	No connection
66	NC	-	No connection
67	NC	-	No connection
68	NC	-	No connection
69	NC	-	No connection
70	NC	-	No connection
71	NC	-	No connection
72	NC	-	No connection
73	OUT42	O	Constant current output 42
74	GND	G	Ground
75	OUT43	O	Constant current output 43
76	OUT44	O	Constant current output 44
77	OUT45	O	Constant current output 45
78	GND	G	Ground
79	OUT46	O	Constant current output 46
80	OUT47	O	Constant current output 47
81	OUT48	O	Constant current output 48
82	ERR_IN	I	Error status input from next driver.
83	PCLK_O	O	Grayscale PWM control output to next driver.
84	BLANK_O	O	BLANK control output to next driver.
85	DO	O	Serial data output to next driver.
86	MODE_O	O	MODE control output to next driver.
87	CLK_O	O	Serial data shift clock output
88	SYNC_O	O	Sync signal for the first channel to latch data
89	VDD	P	Power supply voltage
90	VDD	P	Power supply voltage
91	Rext2	P	Connect an external resistor to setup output current( $I_{O25} \sim I_{O48}$ )
92	AGND	G	Analog ground
93	AGND	G	Analog ground
94	NC	-	No connection
95	NC	-	No connection
96	NC	-	No connection
97	NC	-	No connection
98	NC	-	No connection
99	NC	-	No connection
100	NC	-	No connection
101	NC	-	No connection
102	NC	-	No connection
103	NC	-	No connection
104	NC	-	No connection
105	NC	-	No connection
106	NC	-	No connection
107	NC	-	No connection
108	NC	-	No connection
109	VDD	P	Power supply voltage
110	VDD	P	Power supply voltage
111	Rext1	P	Connect an external resistor to setup output current( $I_{O1} \sim I_{O24}$ )

112	AGND	G	Analog ground
113	AGND	G	Analog ground
114	SYNC_IN	I	Sync signal input
115	CLK_IN	I	Serial data shift clock input
116	MODE_IN	I	Input mode-select pin. When MODE = GND, the driver is in PWM mode. When MODE = VDD, the driver is in CA mode
117	DIN	I	Serial data input
118	BLANK_IN	I	Blank control input to turn off all outputs. When BLANK_IN = H, all outputs are forced OFF and the PWM counter is also reset. When BLANK_IN = L, outputs work under normal condition.
119	PCLK_IN	I	Grayscale PWM control input
120	ERR_O	O	Error status output
121	OUT1	O	Constant current output 1
122	OUT2	O	Constant current output 2
123	OUT3	O	Constant current output 3
124	GND	G	Ground
125	OUT4	O	Constant current output 4
126	OUT5	O	Constant current output 5
127	OUT6	O	Constant current output 6
128	GND	G	Ground

## Package Dimension: LQFP128

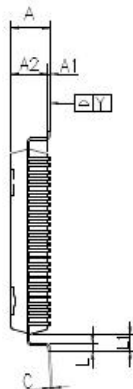
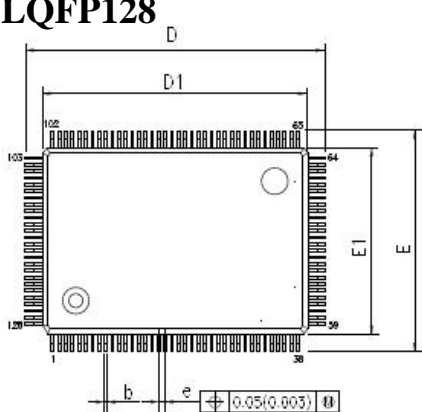

SYMBOLS	MIN.	NOM.	MAX.
A	—	—	1.60
A1	0.05	—	0.15
A2	1.35	1.40	1.45
b	0.17	0.22	0.27
c	0.10	0.15	0.20
D1	—	20.00 BSC	—
E1	—	14.00 BSC	—
e	—	0.50 BSC	—
D	—	22.00 BSC	—
E	—	16.00 BSC	—
L	0.45	0.60	0.75
L1	—	1.00 REF	—
Y	—	—	0.08
φ	φ	3.5	7

UNIT : mm

⚠ THERMALLY ENHANCED DIMENSIONS (SHOWN IN MIN)

PAD SIZE	E2		D2	
	MIN.	MAX.	MIN.	MAX.
315x31E	6.40	8.00	6.40	8.00

NOTES:

1. JEDEC OUTLINE  
MS-026 BHB  
MS-026 BHB-H0 (THERMALLY ENHANCED VARIATIONS ONLY).
2. DATUM PLANE (□) IS LOCATED AT THE BOTTOM OF THE MOLD PARTING LINE COINCIDENT WITH WHERE THE LEAD EXITS THE BODY.
3. DIMENSIONS E1 AND D1 DO NOT INCLUDE MOLD PROTRUSION. ALLOWABLE PROTRUSION IS 0.25 mm PER SIDE. DIMENSIONS E AND E DO INCLUDE MOLD MISMATCH AND ARE DETERMINED AT DATUM PLANE (□).
4. DIMENSION b DOES NOT INCLUDE DAMBAR PROTRUSION.

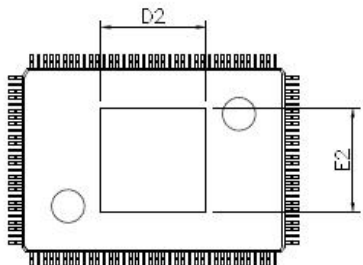
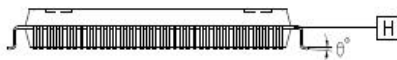

(THERMALLY ENHANCED VARIATIONS ONLY)